

www.tool-moldmaking.com

# European

## TOOL & MOULD MAKING

COMPONENTS • EQUIPMENT • MATERIALS • SOFTWARE • SERVICES

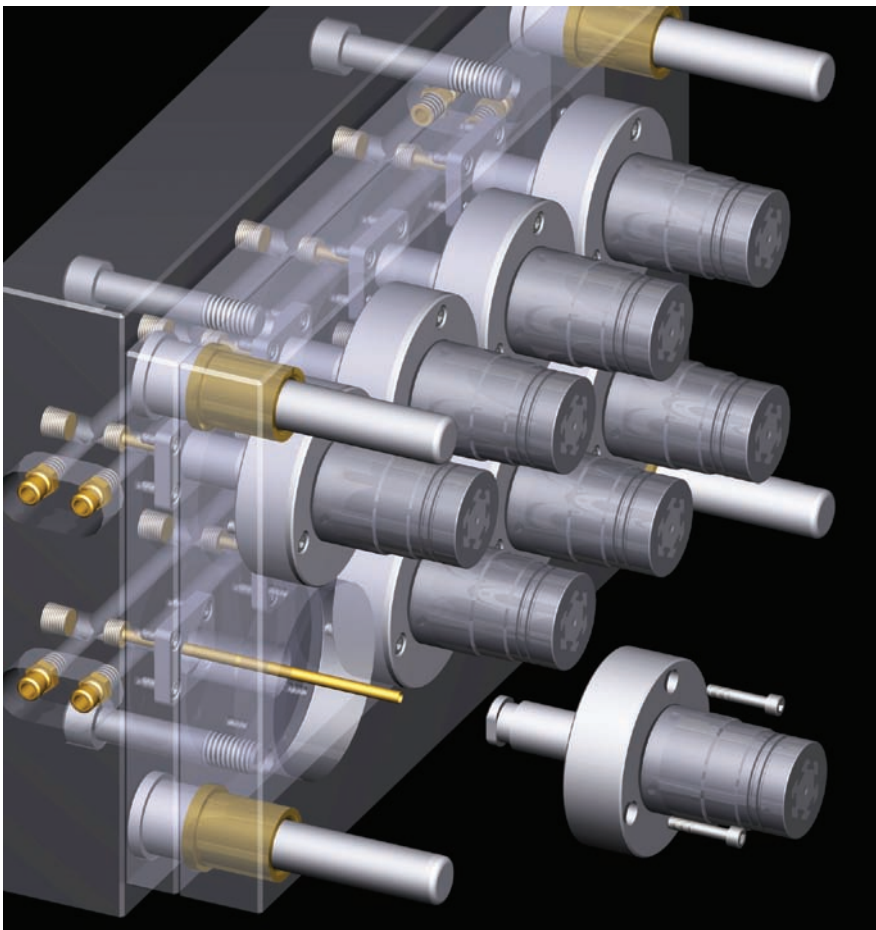

### Space-Saving Collapsible Mould Core Cuts Cycle Times

Progressive Components introduces its new DT-series collapsible core, which can be serviced while the mould is still in the press.

72

IN THIS ISSUE



- Will Electric Cars Put Machine Tools Out of Work?
- The TIPSS Survey: Tooling Goes Global



Sandvik Coromant innovates in its milling cutter line to enable even higher-performance machining.

53



Hardinge offers its latest precision 5-axis VMC in different configurations to suit different manufacturing requirements.

48

## Space-Saving Collapsible Mould Core Cuts Cycle Times, Can Be Serviced While the Mould Is Still in the Press

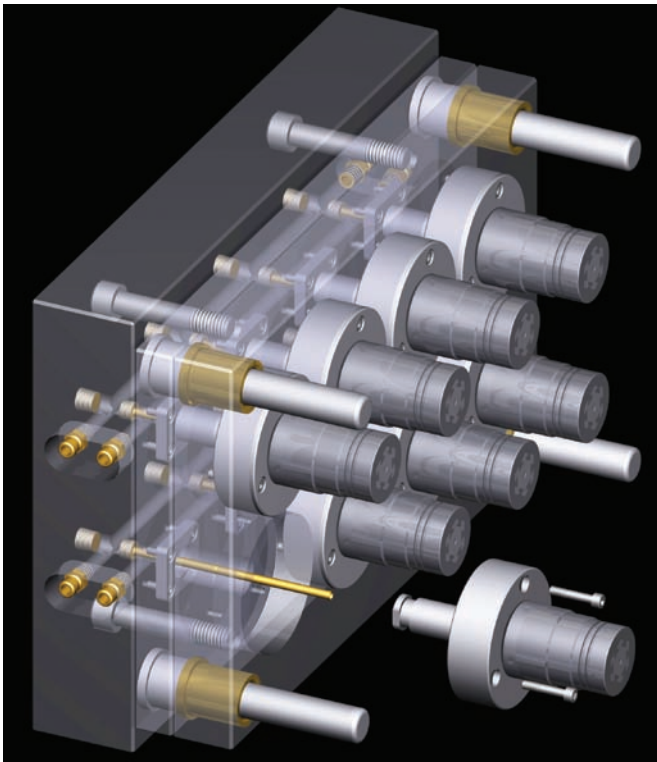

Progressive Components, a US-based supplier of components for the global production tooling industry, has expanded its line of C-Cores with the new DT-series collapsible core. The DT Core is a positive, mechanically actuated collapsible core that eliminates the cycle time requirements of complex gear-and-rack approaches, resulting in a simplified open-shut tool. The maintenance advantage is dramatically evident: a patented quick-lock feature facilitates removal and servicing of the core unit while the mould is still in the press.

The DT Core's compact design allows tighter cavity spacing, which in turn enables a smaller press to be used or more cavities to be added than would be possible with a comparably sized gear-and-rack mould base. In addition, by utilizing the mould opening process to effect actuation, the need for an ejector system is eliminated. The result is a minimal height dimension, which is advantageous in stack moulds and also allows installation on the mould's cavity half.

Available in four standard sizes to match common industry cap diameters, the DT Core can be supplied in custom sizes as well. Progressive can also provide the finished thread detail to help reduce mould building time and expense.

Progressive Components Europe Ltd.

MIDDLETON, MANCHESTER, UK  
[www.etmm.info/2009/11/112](http://www.etmm.info/2009/11/112)

## Innovative Melt-Pressure Sensor Makes Possible Very High Precision in Measuring Nozzle Pressure



Melt pressure in front of the injection moulding machine screw is an important process parameter. Machine control is critically dependent on its precise measurement. Injection-moulded components can be kept within ex-

tremely tight tolerances only if this pressure can be accurately and repeatedly measured and recorded over a long period. That's the impetus behind Kistler Instrumente AG introducing the Type 4021A melt-pressure sensor.

This new sensor is a groundbreaking development based on the piezoresistive principle of measurement. It measures the all-important melt pressure directly in the area before the screw with a reproducibility of better than 0.1%, linearity error of less than 0.5% and zero-point change also within 0.5%.

Kistler supplies the sensor with a flat seal as a complete measuring chain with a new amplifier that also has an output for the melt temperature. The new melt-pressure measuring chain is available for the measurement ranges of 0–100, 0–500, 0–1,000, 0–2,000 and 0–3,000 bar, and can be used at temperatures up to 350°C.

Angled or straight cable exits and a connector version allow it to be used on machines presenting a wide variety of mounting situations.

Kistler Instrumente AG

WINTERTHUR, SWITZERLAND  
[www.etmm.info/2009/11/113](http://www.etmm.info/2009/11/113)